



INFINITY[®]
HDPE WALL SLEEVES



ADVANCE
PRODUCTS & SYSTEMS, INC.

ISO-9001 CERTIFIED COMPANY - FM537405





In the absence of wall sleeves, mechanical/utility piping vibration can cause costly wall damage. Protect your investment and use Infinity® wall sleeves to provide a better seal than a core drilled hole.

INFINITY® HDPE WALL SLEEVES: AN INFINITE HYDROSTATIC SEAL

Infinity® wall sleeves are designed for concrete poured barriers to construct a circular penetration through walls, floors and ceilings. Infinity® HDPE wall sleeves are lightweight for an easy one-man installation. The Infinity® wall sleeve is available in 16 sizes ranging from 2” – 25” in diameter and can accommodate wall thickness up to 16”. Infinity® wall sleeves, combined with our Innerlynx® modular mechanical seals, can withstand up to 40 psig or 92 feet of head pressure. All Infinity® wall sleeves come with two locator caps used to position and attach them to the cement form. The best way to guarantee a perfect seal is to use Infinity® wall sleeves in conjunction with Innerlynx® modular mechanical seals. They’re engineered and sized to provide a stable hole that matches dimensionally with Innerlynx® modular mechanical seals. This makes ordering quick and easy and guarantees a perfect fit every time.

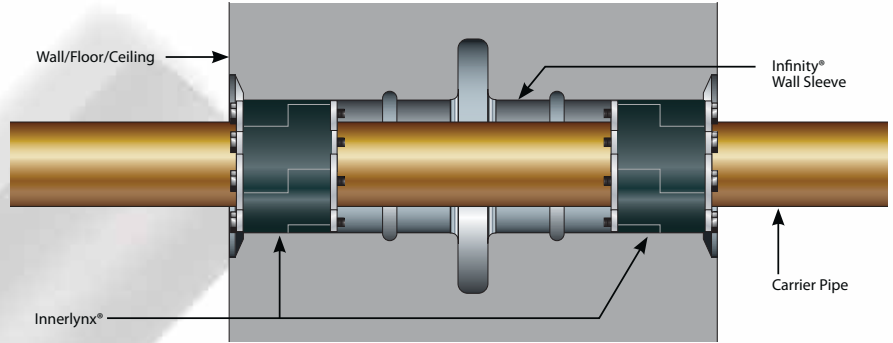

FEATURES AND BENEFITS

**16 sizes
(2” – 25” in diameter)**

Infinity® wall sleeves come in lengths of 16” from the factory but can be cut to the desired length in accordance with the thickness of the concrete wall (We highly recommend that they be cut to size on site as dimensions often change in the field).

Made of HDPE

High density polyethylene provides excellent resistance to acids, alkalis and other organic solvents. Ideal for cathodic protection systems, these nonconductive sleeves will never rust or corrode. Infinity® wall sleeves can withstand temperatures up to 150 °F.

Lighter than steel

Infinity® wall sleeves are light enough for one worker to install without a hoist or helper reducing installation time and keeping labor cost down. Infinity® wall sleeves are easy to stock and much cheaper to ship than steel wall sleeves.

Positive hydrostatic seal

Innerlynx® modular mechanical seals are rated at 40 psig (92.28 feet of head pressure) and are available in 5 different models and 21 sizes to accommodate any application.

Resist water migration

Infinity® wall sleeves are manufactured with 2” water stops to prevent water seepage around the outside of the penetration. The water stops also act as a thrust barrier so the sleeve cannot be pulled out.

Adjust to wall thickness

Infinity® wall sleeves’ unique hollow water stop collar acts like an expansion joint adjusting up to ½” to the thickness of the wall. The compression force pushes against the forms like a spring creating tension to maintain proper sleeve location.

Locator caps

Specially designed locator caps provide an ideal method for attaching the Infinity® wall sleeves to concrete forms. The locator caps ensure that the sleeve holds its circular configuration during the pour and prevents wet concrete from entering the sleeve.

WEIGHTS & DIMENSIONS

Model	ID (in.)	ID (mm)	lbs.
IS-2	1.950	49.53	1.06
IS-3	2.890	73.41	1.68
IS-3.5	3.360	85.34	1.85
IS-4	3.970	100.84	2.08
IS-5	5.110	129.79	2.82
IS-6	6.110	155.19	3.44
IS-8	8.125	206.38	5.00
IS-10	10.090	256.29	6.41
IS-12	12.070	306.58	9.06
IS-14	13.930	353.82	10.03
IS-16	16.050	407.67	12.01
IS-18	17.220	437.39	13.67
IS-20	18.920	480.57	14.24
IS-22	20.125	511.18	15.00
IS-24	22.563	573.10	17.70
IS-25	24.750	628.65	19.13

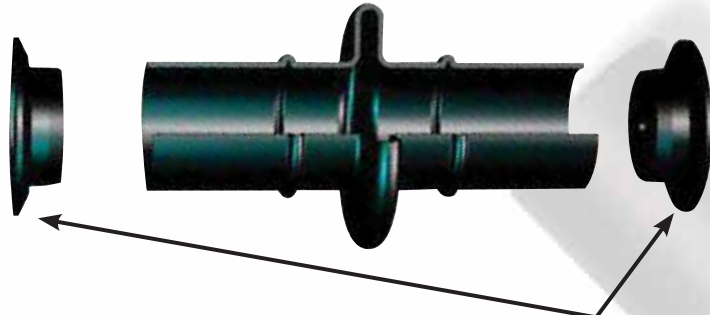

Infinity® Locator Caps



INSTALLATION



1. Using a tape measure, pull measurements from the horizontal and vertical positions to locate the center of the Infinity® wall sleeve.



2. Screw or nail one of the locator caps at the center line.



3. Cut the Infinity® wall sleeve $\frac{3}{4}$ " shorter than the wall thickness (+/-1/4"), then insert the sleeve over the locator cap.



4. Insert the second locator cap.



5. Attach the Infinity® wall sleeve to the rebar using wire.



6. After concrete is cured, pry off the locator caps with a pry bar.

ALTERNATE INSTALLATION UTILIZING THREADED ROD



1. Extend (threaded rod*) through form and first locator cap and (threaded nut*) on the back side of form.



2. Attach Infinity® wall sleeve to locator cap.



3. Slide second locator cap through (threaded rod*), use fender washer and fasten nut until locator caps and sleeve are locked in place. Check to make sure sleeve is square to form.

*Not provided by APS

BEFORE ORDERING, ENSURE THAT :

1. O.D. of carrier pipe leaves room for Innerlynx®.
Ask APS for assistance if uncertain.
2. Wall thickness is less than 16". For thicker walls, contact APS for assistance.
3. Innerlynx® have been ordered to complete the project.

OTHER PRODUCTS AVAILABLE

- Flange Isolating Gasket Kits
- UBolt-Cote® and Atlas® Pipe Support Pads
- Casing Spacers and End Seals
- Gal-vo-plast® Wall Sleeves
- Innerlynx® Modular Mechanical Seals
- Foreman Nite Caps - temporary pipe plugs
- Kleerband® Flange Band Protectors
- Radolid® Bolt and Nut Protection Caps



PO Box 60399 • Lafayette, Louisiana 70596-0399
800-315-6009 • 337-233-6116 • FAX 337-232-3860

E-Mail: sales@apsonline.com • Website: www.apsonline.com



Distributed by:

CORROSION SERVICE
AN AUTHORIZED APS DISTRIBUTOR:
www.corrosionservice.com
material_orders@corrosionservice.com
+1 (800) 676 4984

Advance Products & Systems, Inc. is not responsible for errors printed in this brochure.

Advance Products & Systems, Inc. shall repair or replace (within the limitations of such applicable express written warranty as may be issued by it) any product or portions thereof, which prove to be defective in workmanship or material for a period of 12 months from shipment date. The foregoing in lieu of all warranties, express or implied, and all other obligations or liabilities on the part of APS, on account of the product which it may sell. In no event shall APS be liable for consequential or special damages: nor except as it may otherwise specifically agree in writing, installation, or other work which may be done upon or in connection with the product by APS/the distribution/dealer or others. THE LIMITED WARRANTIES PROVIDED IN THIS AGREEMENT AND THE OBLIGATIONS AND LIABILITIES OF APS ARE THE ONLY WARRANTIES MADE BY APS AS TO THE PRODUCT. APS MAKES NO EXPRESS OR OTHER IMPLIED WARRANTIES, BY COURSE OF DEALING, USAGE OF TRADE, MERCHANTABILITY, FITNESS FOR A PARTICULAR USE (WHETHER GENERAL OR SPECIFIC), OR OTHERWISE.